

## 1. General Description

The 74LVC8T245; 74LVCH8T245 is an 8-bit dual supply translating transceivers with 3-state outputs that enable bidirectional level translation. They feature two data input-output ports (pins An and Bn), a direction control input (DIR), an output enable input ( $\overline{OE}$ ) and dual supply pins ( $V_{CC(A)}$  and  $V_{CC(B)}$ ). Both  $V_{CC(A)}$  and  $V_{CC(B)}$  can be supplied at any voltage between 1.2 V and 5.5 V making the device suitable for translating between any of the low voltage nodes (1.2 V, 1.5 V, 1.8 V, 2.5 V, 3.3 V and 5.0 V). Pins An,  $\overline{OE}$  and DIR are referenced to  $V_{CC(A)}$  and pins Bn are referenced to  $V_{CC(B)}$ . A HIGH on DIR allows transmission from An to Bn and a LOW on DIR allows transmission from Bn to An. The output enable input ( $\overline{OE}$ ) can be used to disable the outputs so the buses are effectively isolated.

The devices are fully specified for partial power-down applications using  $I_{OFF}$ . The  $I_{OFF}$  circuitry disables the output, preventing any damaging backflow current through the device when it is powered down. In suspend mode when either  $V_{CC(A)}$  or  $V_{CC(B)}$  are at GND level, both A port and B port are in the high-impedance OFF-state.

Active bus hold circuitry in the 74LVCH8T245 holds unused or floating data inputs at a valid logic level.

## 2. Features and Benefits

### ■ Wide supply voltage range

- $V_{CC(A)}$ : 1.2 V to 5.5 V
- $V_{CC(B)}$ : 1.2 V to 5.5 V

### ■ High noise immunity

### ■ Complies with JEDEC standards:

- JESD8-7 (1.2 V to 1.95 V)
- JESD8-5 (1.8 V to 2.7 V)
- JESD8C (2.7 V to 3.6 V)
- JESD36 (4.5 V to 5.5 V)

### ■ Suspend mode

# 74LVC8T245; 74LVCH8T245



## 8-bit dual supply translating transceiver; 3-state

Draft datasheet, Rev. 1.0

Aug 08, 2024

- Latch-up performance exceeds 250 mA
- $\pm 24$  mA output drive ( $V_{CC} = 3.0$  V)
- Inputs accept voltages up to 5.5 V
- Low power consumption: 30  $\mu$ A maximum  $I_{CC}$
- $I_{OFF}$  circuitry provides partial Power-down mode operation
- ESD protection:
  - HBM ANSI/ESDA/JEDEC JS-001 Class 2 exceeds 2500 V
  - CDM ANSI/ESDA/JEDEC JS-002 Class C3 exceeds 2000 V
- Multiple package options

### 3. Ordering Information

Table 1. Ordering information

Type number	Package		
	Name	Description	Quantity
74LVC8T245PW	TSSOP-24L	plastic thin shrink small outline package; 24 leads; body width 4.4 mm	2500
74LVCH8T245PW			

### 4. Function Diagram

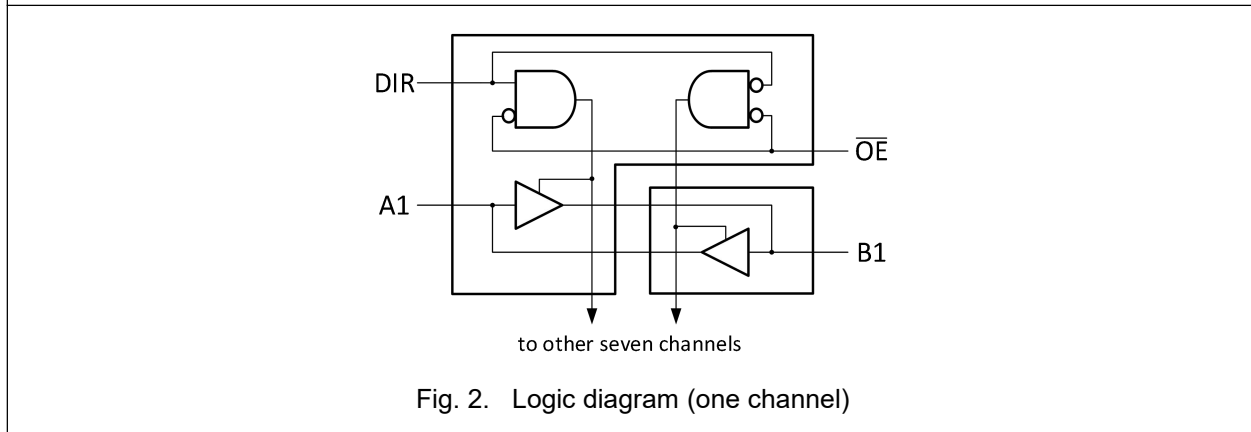
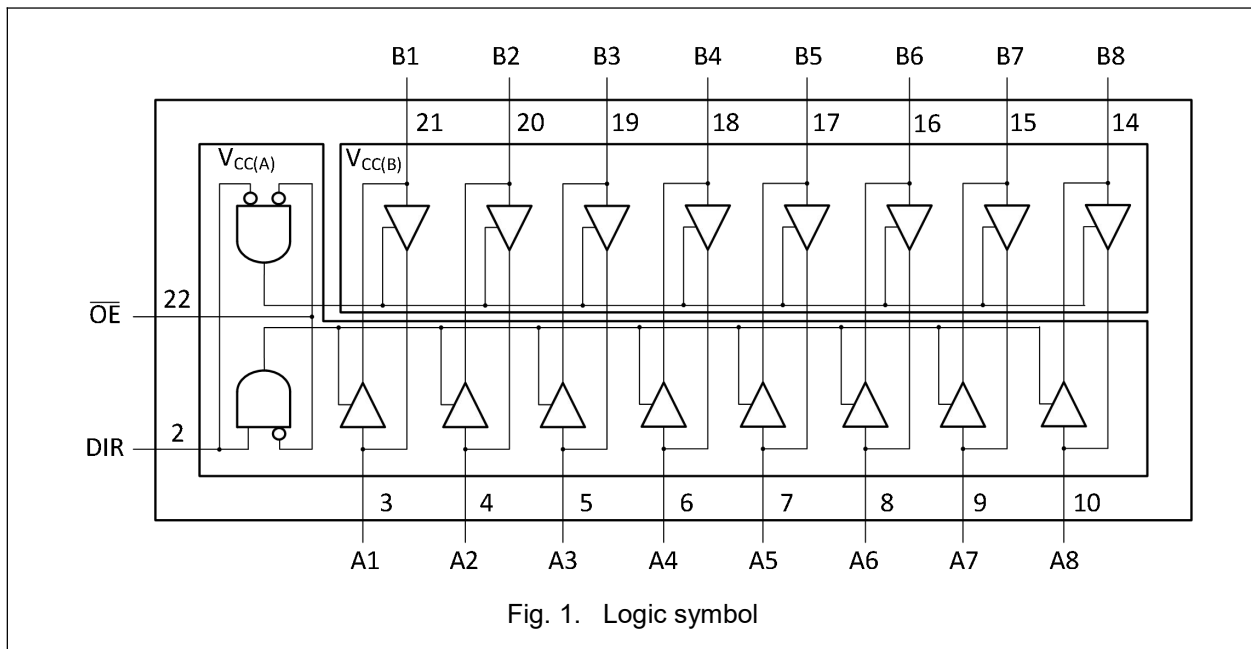

## 5. Pinning Information

### 5.1. Pinning

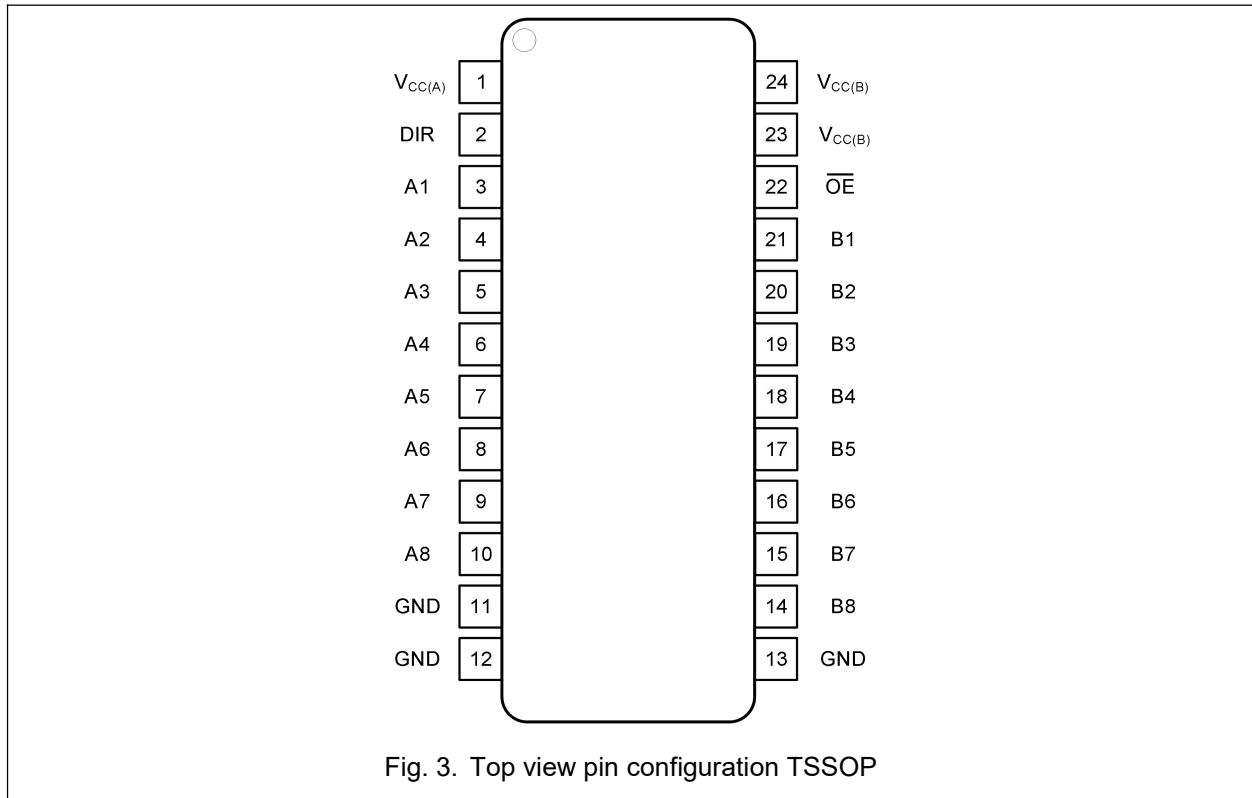

Fig. 3. Top view pin configuration TSSOP

### 5.2. Pin description

Table 2. Pin description

Symbol	Pin	Description
$V_{CC(A)}$	1	Supply voltage A (An inputs/outputs, $\overline{OE}$ and DIR inputs are referenced to $V_{CC(A)}$ )
DIR	2	Direction control
A1, A2, A3, A4, A5, A6, A7, A8	3, 4, 5, 6, 7, 8, 9, 10	Data input or output
GND [1]	11, 12, 13	Ground (0 V)
B1, B2, B3, B4, B5, B6, B7, B8	21, 20, 19, 18, 17, 16, 15, 14	Data input or output
$\overline{OE}$	22	Output enable input (active LOW)
$V_{CC(B)}$	23, 24	Supply voltage B (Bn inputs/outputs are referenced to $V_{CC(B)}$ )

[1] All GND pins must be connected to ground (0V).

## 6. Functional Description

**Table 3. Function table**

H = HIGH voltage level; L = LOW voltage level; X = don't care; Z = high-impedance OFF-state.

Supply voltage	Input		Input/output	
	$\overline{OE}$ [2]	DIR [2]	An [2]	Bn [2]
1.2 V to 5.5 V	L	L	A = B	input
1.2 V to 5.5 V	L	H	input	B = A
1.2 V to 5.5 V	H	X	Z	Z
GND [1]	X	X	Z	Z

[1] If at least one of  $V_{CC(A)}$  or  $V_{CC(B)}$  is at GND level, the device goes into suspend mode.

[2] The An inputs/outputs, DIR and OE input circuit is referenced to  $V_{CC(A)}$ ; The Bn inputs/outputs circuit is referenced to  $V_{CC(B)}$ .

## 7. Absolute Maximum Ratings

Stresses exceeding the absolute maximum ratings may damage the device. The device may not function or be operable above the recommended operating conditions and stressing the parts to these levels is not recommended. In addition, extended exposure to stresses above the recommended operating conditions may affect device reliability. The absolute maximum ratings are stress ratings only.

**Table 4. Absolute Maximum Ratings**

In accordance with the Absolute Maximum Rating System (IEC 60134). Voltages are referenced to GND.

Symbol	Parameter	Conditions	Min	Max	Unit
$V_{CC(A)}$	supply voltage A		-0.5	6.5	V
$V_{CC(B)}$	supply voltage B		-0.5	6.5	V
$I_{IK}$	input clamping current	$V_I < 0$ V	-50		mA
$V_I$	input voltage	[1]	-0.5	6.5	V
$I_{OK}$	output clamping current	$V_O < 0$ V	-50		mA
$V_O$	output voltage	Active mode [1][2][3]	-0.5	$V_{CCO} + 0.5$	V
		Suspend or 3-state mode [1]	-0.5	6.5	V
$I_O$	output current	$V_O = 0$ V to $V_{CCO}$ [2]		$\pm 50$	mA
$I_{CC}$	supply current	$I_{CC(A)}$ or $I_{CC(B)}$ ; per $V_{CC}$ pin		100	mA
$I_{GND}$	ground current	per GND pin	-100		mA
$P_{tot}$	total power dissipation			500	mW
$T_{stg}$	storage temperature		-65	150	°C

[1] The input and output voltage ratings may be exceeded if the input and output current ratings are observed.

[2]  $V_{CCO}$  is the supply voltage associated with the output port.

[3]  $V_{CCO} + 0.5$  V should not exceed 6.5 V.

## 8. Recommended Operating Conditions

The Recommended Operating Conditions table defines the conditions for actual device operation. Recommended operating conditions are specified to ensure optimal performance to the datasheet specifications. MDD does not recommend exceeding them or designing to Absolute Maximum Ratings.

**Table 5. Recommended Operating Conditions**

Symbol	Parameter	Conditions	Min	Max	Unit
$V_{CC(A)}$	supply voltage A		1.2	5.5	V
$V_{CC(B)}$	supply voltage B		1.2	5.5	V
$V_I$	input voltage		0	5.5	V
$V_O$	output voltage	Active mode [1]	0	$V_{CCO}$	V
		Suspend or 3-state mode	0	5.5	V
$T_{amb}$	ambient temperature		-40	125	°C
$\Delta t/\Delta V$	input transition rise and fall rate	$V_{CCI} = 1.2 \text{ V}$ [2]		20	ns/V
		$V_{CCI} = 1.4 \text{ V to } 1.95 \text{ V}$		20	ns/V
		$V_{CCI} = 2.3 \text{ V to } 2.7 \text{ V}$		20	ns/V
		$V_{CCI} = 3 \text{ V to } 3.6 \text{ V}$		10	ns/V
		$V_{CC} = 4.5 \text{ V to } 5.5 \text{ V}$		5	ns/V

[1]  $V_{CCO}$  is the supply voltage associated with the output port.

[2]  $V_{CCI}$  is the supply voltage associated with the input port.

## 9. Static Characteristics

**Table 6. Static characteristics**

At recommended operating conditions. Voltages are referenced to GND (ground = 0 V). Typical values measured at  $T_{amb} = 25^{\circ}\text{C}$  (unless otherwise noted).

Symbol	Parameter	Conditions	-40 °C to +85 °C			-40 °C to +125 °C		Unit
			Min	Typ	Max	Min	Max	
$V_{IH}$	HIGH-level input voltage	data input [1]						
		$V_{CCI} = 1.2\text{ V}$	$0.8V_{CCI}$			$0.8V_{CCI}$		V
		$V_{CCI} = 1.4\text{ V to }1.95\text{ V}$	$0.65V_{CCI}$			$0.65V_{CCI}$		V
		$V_{CCI} = 2.3\text{ V to }2.7\text{ V}$	1.7			1.7		V
		$V_{CCI} = 3\text{ V to }3.6\text{ V}$	2.2			2.2		V
		$V_{CCI} = 4.5\text{ V to }5.5\text{ V}$	$0.7V_{CCI}$			$0.7V_{CCI}$		V
		DIR, $\overline{OE}$ input						
		$V_{CCI} = 1.2\text{ V}$	$0.8V_{CC(A)}$			$0.8V_{CC(A)}$		V
		$V_{CCI} = 1.4\text{ V to }1.95\text{ V}$	$0.65V_{CC(A)}$			$0.65V_{CC(A)}$		V
		$V_{CCI} = 2.3\text{ V to }2.7\text{ V}$	1.7			1.7		V
		$V_{CCI} = 3\text{ V to }3.6\text{ V}$	2.0			2.0		V
		$V_{CCI} = 4.5\text{ V to }5.5\text{ V}$	$0.7V_{CC(A)}$			$0.7V_{CC(A)}$		V
$V_{IL}$	LOW-level input voltage	data input [1]						
		$V_{CCI} = 1.2\text{ V}$			$0.2V_{CCI}$		$0.2V_{CCI}$	V
		$V_{CCI} = 1.4\text{ V to }1.95\text{ V}$			$0.35 V_{CCI}$		$0.35 V_{CCI}$	V
		$V_{CCI} = 2.3\text{ V to }2.7\text{ V}$			0.7		0.7	V
		$V_{CCI} = 3\text{ V to }3.6\text{ V}$			0.8		0.8	V
		$V_{CCI} = 4.5\text{ V to }5.5\text{ V}$			$0.3V_{CCI}$		$0.3V_{CCI}$	V
		DIR, $\overline{OE}$ input						
		$V_{CCI} = 1.2\text{ V}$			$0.2V_{CC(A)}$		$0.2V_{CC(A)}$	V
		$V_{CCI} = 1.4\text{ V to }1.95\text{ V}$			$0.35 V_{CC(A)}$		$0.35 V_{CC(A)}$	V
		$V_{CCI} = 2.3\text{ V to }2.7\text{ V}$			0.7		0.7	V
		$V_{CCI} = 3\text{ V to }3.6\text{ V}$			0.8		0.8	V
		$V_{CCI} = 4.5\text{ V to }5.5\text{ V}$			$0.3V_{CC(A)}$		$0.3V_{CC(A)}$	V

**74LVC8T245; 74LVCH8T245**
**8-bit dual supply translating transceiver; 3-state**

Symbol	Parameter	Conditions	-40 °C to +85 °C			-40 °C to +125 °C		Unit
			Min	Typ	Max	Min	Max	
V <sub>OH</sub>	HIGH-level output voltage	V <sub>I</sub> = V <sub>IH</sub>						
		I <sub>O</sub> = -100 μA; V <sub>CCO</sub> = 1.2 V to 4.5 V	V <sub>CCO</sub> - 0.1			V <sub>CCO</sub> - 0.1		V
		I <sub>O</sub> = -3 mA; V <sub>CCO</sub> = 1.4 V	1.0			1.0		V
		I <sub>O</sub> = -8 mA; V <sub>CCO</sub> = 1.65 V	1.2			1.2		V
		I <sub>O</sub> = -12 mA; V <sub>CCO</sub> = 2.3 V	1.9			1.9		V
		I <sub>O</sub> = -24 mA; V <sub>CCO</sub> = 3.0 V	2.4			2.4		V
		I <sub>O</sub> = -32 mA; V <sub>CCO</sub> = 4.5 V	3.8			3.8		V
V <sub>OL</sub>	LOW-level output voltage	V <sub>I</sub> = V <sub>IL</sub>						
		I <sub>O</sub> = 100 μA; V <sub>CCO</sub> = 1.2 V to 4.5 V			0.1		0.1	V
		I <sub>O</sub> = 3 mA; V <sub>CCO</sub> = 1.4 V			0.3		0.3	V
		I <sub>O</sub> = 8 mA; V <sub>CCO</sub> = 1.65 V			0.45		0.45	V
		I <sub>O</sub> = 12 mA; V <sub>CCO</sub> = 2.3 V			0.3		0.3	V
		I <sub>O</sub> = 24 mA; V <sub>CCO</sub> = 3.0 V			0.55		0.55	V
		I <sub>O</sub> = 32 mA; V <sub>CCO</sub> = 4.5 V			0.55		0.55	V
I <sub>I</sub>	input leakage current	DIR, $\overline{OE}$ input; V <sub>I</sub> = 0 V to 5.5 V; V <sub>CCI</sub> = 1.2 V to 5.5 V			±2		±10	μA
I <sub>OZ</sub>	OFF-state output current	A or B port; V <sub>O</sub> = 0 V or V <sub>CCO</sub> ; V <sub>CCO</sub> = 1.2 V to 5.5 V [2]			±2		±10	μA
		suspend mode A port; V <sub>O</sub> = 0 V or V <sub>CCO</sub> ; V <sub>CC(A)</sub> = 5.5 V; V <sub>CC(B)</sub> = 0 V [2]			±2		±10	μA
		suspend mode B port; V <sub>O</sub> = 0 V or V <sub>CCO</sub> ; V <sub>CC(A)</sub> = 0 V; V <sub>CC(B)</sub> = 5.5 V [2]			±2		±10	μA
I <sub>OFF</sub>	power-off leakage current	A port; V <sub>I</sub> or V <sub>O</sub> = 0 V to 5.5 V; V <sub>CC(A)</sub> = 0 V; V <sub>CC(B)</sub> = 1.2 V to 5.5 V			±2		±10	μA
		B port; V <sub>I</sub> or V <sub>O</sub> = 0 V to 5.5 V;			±2		±10	μA

**74LVC8T245; 74LVCH8T245**
**8-bit dual supply translating transceiver; 3-state**

		$V_{CC(B)} = 0\text{ V}; V_{CC(A)} = 1.2\text{ V to } 5.5\text{ V}$						
--	--	---	--	--	--	--	--	--

Symbol	Parameter	Conditions	-40 °C to +85 °C			-40 °C to +125 °C		Unit
			Min	Typ	Max	Min	Max	
$I_{BHL}$	bus hold LOW current	A or B port [1]						
		$V_I = 0.58\text{ V}; V_{CCI} = 1.65\text{ V}$	25			20		$\mu\text{A}$
		$V_I = 0.70\text{ V}; V_{CCI} = 2.3\text{ V}$	45			45		$\mu\text{A}$
		$V_I = 0.80\text{ V}; V_{CCI} = 3.0\text{ V}$	100			80		$\mu\text{A}$
		$V_I = 1.35\text{ V}; V_{CCI} = 4.5\text{ V}$	100			100		$\mu\text{A}$
$I_{BHH}$	bus hold HIGH current	A or B port [1]						
		$V_I = 1.07\text{ V}; V_{CCI} = 1.65\text{ V}$	-1			-1		$\mu\text{A}$
		$V_I = 1.70\text{ V}; V_{CCI} = 2.3\text{ V}$	-7			-7		$\mu\text{A}$
		$V_I = 2.00\text{ V}; V_{CCI} = 3.0\text{ V}$	-35			-35		$\mu\text{A}$
		$V_I = 3.15\text{ V}; V_{CCI} = 4.5\text{ V}$	-95			-95		$\mu\text{A}$
$I_{BHLO}$	bus hold LOW overdrive current	A or B port [1][3]						
		$V_{CCI} = 1.6\text{ V}$	125			125		$\mu\text{A}$
		$V_{CCI} = 1.95\text{ V}$	200			200		$\mu\text{A}$
		$V_{CCI} = 2.7\text{ V}$	300			300		$\mu\text{A}$
		$V_{CCI} = 3.6\text{ V}$	500			500		$\mu\text{A}$
		$V_{CCI} = 5.5\text{ V}$	900			900		$\mu\text{A}$
$I_{BHHO}$	bus hold HIGH overdrive current	A or B port [1][3]						
		$V_{CCI} = 1.6\text{ V}$	-125			-125		$\mu\text{A}$
		$V_{CCI} = 1.95\text{ V}$	-200			-200		$\mu\text{A}$
		$V_{CCI} = 2.7\text{ V}$	-300			-300		$\mu\text{A}$
		$V_{CCI} = 3.6\text{ V}$	-500			-500		$\mu\text{A}$
		$V_{CCI} = 5.5\text{ V}$	-900			-900		$\mu\text{A}$

## 74LVC8T245; 74LVCH8T245

### 8-bit dual supply translating transceiver; 3-state

Symbol	Parameter	Conditions	-40 °C to +85 °C			-40 °C to +125 °C		Unit
			Min	Typ	Max	Min	Max	
$I_{CC}$	supply current	A port; $V_I = 0\text{ V}$ or $V_{CCI}$ ; $I_O = 0\text{ A}$ [1]						
		$V_{CC(A)}, V_{CC(B)} = 1.2\text{V to } 5.5\text{V}$			15		20	$\mu\text{A}$
		$V_{CC(A)} = 5.5\text{V}; V_{CC(B)} = 0\text{V}$			15		20	$\mu\text{A}$
		$V_{CC(A)} = 0\text{V}; V_{CC(B)} = 5.5\text{V}$	-2			-4		$\mu\text{A}$
		B port; $V_I = 0\text{ V}$ or $V_{CCI}$ ; $I_O = 0\text{ A}$						
		$V_{CC(A)}, V_{CC(B)} = 1.2\text{V to } 5.5\text{V}$			15		20	$\mu\text{A}$
		$V_{CC(B)} = 0\text{V}; V_{CC(A)} = 5.5\text{V}$	-2			-4		$\mu\text{A}$
		$V_{CC(B)} = 5.5\text{V}; V_{CC(A)} = 0\text{V}$			15		20	$\mu\text{A}$
		A plus B port ( $I_{CC(A)} + I_{CC(B)}$ ); $I_O = 0\text{ A}; V_I = 0\text{ V}$ or $V_{CCI}$						
		$V_{CC(A)}, V_{CC(B)} = 1.2\text{V to } 5.5\text{V}$			25		30	$\mu\text{A}$
$\Delta I_{CC}$	additional supply current	per input; $V_{CC(A)}, V_{CC(B)} = 3.0\text{V to } 5.5\text{V}$						
		DIR and $\overline{OE}$ input; DIR or $\overline{OE}$ input at $V_{CC(A)} - 0.6\text{V}$ ; A port at $V_{CC(A)}$ or GND; B port = open			50		75	$\mu\text{A}$
		A port; A port at $V_{CC(A)} - 0.6\text{ V}$ ; DIR at $V_{CC(A)}$ ; B port = open [4]			50		75	$\mu\text{A}$
		B port; B port at $V_{CC(B)} - 0.6\text{ V}$ ; DIR at $V_{CC(B)}$ ; A port = open [4]			50		75	$\mu\text{A}$

[1]  $V_{CCI}$  is the supply voltage associated with the data input port.

[2]  $V_{CCO}$  is the supply voltage associated with the output port.

[3] To guarantee the node switches, an external driver must source/sink at least  $I_{BHLO} / I_{BHHO}$  when the input is in the range  $V_{IL}$  to  $V_{IH}$ .

[4] For non bus hold parts only (74LVC8T245).

## 10. Dynamic Characteristics

**Table 7. Dynamic characteristics for temperature range -40 °C to +85 °C**

Voltages are referenced to GND (ground = 0 V); for test circuit see Fig. 6. for waveforms see Fig. 3 and Fig. 4. [1]

Symbol	Parameter	Conditions	$V_{CC(B)}$										Unit
			1.5V±0.1V		1.8V±0.15V		2.5V±0.2V		3.3V±0.3V		5.0V±0.5V		
			Min	Max	Min	Max	Min	Max	Min	Max	Min	Max	
<b><math>V_{CC(A)} = 1.5 V \pm 0.1 V</math></b>													
$t_{pd}$	propagation time	An to Bn	0.9	43.2	0.9	39.2	0.8	36.3	0.7	35.1	0.7	35.1	ns
		Bn to An	0.9	43.2	0.9	39.2	0.8	36.3	0.7	35.1	0.7	35.1	ns
$t_{dis}$	disable time	$\overline{OE}$ to An	1.5	72.5	1.5	72.5	1.5	72.5	1.5	72.5	1.4	72.5	ns
		$\overline{OE}$ to Bn	1.5	72.5	1.5	72.5	1.5	72.5	1.5	72.5	1.4	72.5	ns
$t_{en}$	enable time	$\overline{OE}$ to An	0.4	92.2	0.4	92.2	0.4	92.2	0.4	92.2	0.4	92.2	ns
		$\overline{OE}$ to Bn	0.4	92.2	0.4	92.2	0.4	92.2	0.4	92.2	0.4	92.2	ns
<b><math>V_{CC(A)} = 1.8 V \pm 0.15 V</math></b>													
$t_{pd}$	propagation time	An to Bn	0.9	38.6	0.9	30.5	0.8	26.9	0.7	26.3	0.7	25.8	ns
		Bn to An	0.9	38.6	0.9	30.5	0.8	26.9	0.7	26.3	0.7	25.8	ns
$t_{dis}$	disable time	$\overline{OE}$ to An	1.5	46.3	1.5	46.3	1.5	46.3	1.5	46.3	1.4	46.3	ns
		$\overline{OE}$ to Bn	1.5	46.3	1.5	46.3	1.5	46.3	1.5	46.3	1.4	46.3	ns
$t_{en}$	enable time	$\overline{OE}$ to An	0.4	63.2	0.4	58.1	0.4	54.6	0.4	54.1	0.4	53.1	ns
		$\overline{OE}$ to Bn	0.4	63.2	0.4	58.1	0.4	54.6	0.4	54.1	0.4	53.1	ns
<b><math>V_{CC(A)} = 2.5 V \pm 0.2 V</math></b>													
$t_{pd}$	propagation time	An to Bn	1.2	33.0	1.2	24.7	1.0	19.7	1.0	18.3	0.9	17.1	ns
		Bn to An	1.2	33.0	1.2	24.7	1.0	19.7	1.0	18.3	0.9	17.1	ns
$t_{dis}$	disable time	$\overline{OE}$ to An	1.4	25.1	1.4	25.1	1.4	25.1	1.4	25.1	1.4	25.1	ns
		$\overline{OE}$ to Bn	1.4	25.1	1.4	25.1	1.4	25.1	1.4	25.1	1.4	25.1	ns
$t_{en}$	enable time	$\overline{OE}$ to An	1.0	38.3	1.0	33.1	1.0	29.5	1.0	28.0	1.0	27.0	ns
		$\overline{OE}$ to Bn	1.0	38.3	1.0	33.1	1.0	29.5	1.0	28.0	1.0	27.0	ns
<b><math>V_{CC(A)} = 3.3 V \pm 0.3 V</math></b>													
$t_{pd}$	propagation time	An to Bn	0.8	31.2	0.8	22.6	0.8	16.2	0.7	14.5	0.6	13.6	ns
		Bn to An	0.8	31.2	0.8	22.6	0.8	16.2	0.7	14.5	0.6	13.6	ns
$t_{dis}$	disable time	$\overline{OE}$ to An	1.6	20.2	1.6	20.2	1.6	20.2	1.6	20.2	1.6	20.2	ns
		$\overline{OE}$ to Bn	1.6	20.2	1.6	20.2	1.6	20.2	1.6	20.2	1.6	20.2	ns
$t_{en}$	enable time	$\overline{OE}$ to An	0.8	31.5	0.8	25.8	0.8	22.4	0.8	21.1	0.8	20.8	ns
		$\overline{OE}$ to Bn	1.8	31.5	0.8	25.8	0.8	22.4	0.8	21.1	0.8	20.8	ns
<b><math>V_{CC(A)} = 5.0 V \pm 0.5 V</math></b>													
$t_{pd}$	propagation time	An to Bn	0.7	29.8	0.7	21.3	0.4	14.8	0.3	12.6	0.3	11.2	ns
		Bn to An	0.7	29.8	0.7	21.3	0.4	14.8	0.3	12.6	0.3	11.2	ns
$t_{dis}$	disable time	$\overline{OE}$ to An	0.3	15.6	0.3	15.6	0.3	15.6	0.3	15.6	0.3	15.6	ns
		$\overline{OE}$ to Bn	0.3	15.6	0.3	15.6	0.3	15.6	0.3	15.6	0.3	15.6	ns
$t_{en}$	enable time	$\overline{OE}$ to An	0.7	29.1	0.7	21.2	0.7	18.5	0.7	16.8	0.7	15.9	ns
		$\overline{OE}$ to Bn	0.7	29.1	0.7	21.2	0.7	18.5	0.7	16.8	0.7	15.9	ns

 [1]  $t_{pd}$  is the same as  $t_{PLH}$  and  $t_{PHL}$ ;  $t_{dis}$  is the same as  $t_{PLZ}$  and  $t_{PHZ}$ ;  $t_{en}$  is the same as  $t_{PZL}$  and  $t_{PZH}$ .

## 74LVC8T245; 74LVCH8T245

### 8-bit dual supply translating transceiver; 3-state

**Table 8. Dynamic characteristics for temperature range -40 °C to +125 °C**

Voltages are referenced to GND (ground = 0 V); for test circuit see Fig. 6. for waveforms see Fig. 3 and Fig. 4. [1]

Symbol	Parameter	Conditions	V <sub>CC(B)</sub>										Unit
			1.5V±0.1V		1.8V±0.15V		2.5V±0.2V		3.3V±0.3V		5.0V±0.5V		
			Min	Max	Min	Max	Min	Max	Min	Max	Min	Max	
<b>V<sub>CC(A)</sub> = 1.5 V ± 0.1 V</b>													
t <sub>pd</sub>	propagation time	An to Bn	0.9	43.3	0.9	38.9	0.8	36.3	0.7	35.1	0.7	35.1	ns
		Bn to An	0.9	43.3	0.9	38.9	0.8	36.3	0.7	35.1	0.7	35.1	ns
t <sub>dis</sub>	disable time	$\overline{\text{OE}}$ to An	1.5	74.5	1.5	74.5	1.5	74.5	1.5	74.5	1.4	74.5	ns
		$\overline{\text{OE}}$ to Bn	1.5	74.5	1.5	74.5	1.5	74.5	1.5	74.5	1.4	74.5	ns
t <sub>en</sub>	enable time	$\overline{\text{OE}}$ to An	0.4	94.2	0.4	94.2	0.4	94.2	0.4	94.2	0.4	94.2	ns
		$\overline{\text{OE}}$ to Bn	0.4	94.2	0.4	94.2	0.4	94.2	0.4	94.2	0.4	94.2	ns
<b>V<sub>CC(A)</sub> = 1.8 V ± 0.15 V</b>													
t <sub>pd</sub>	propagation time	An to Bn	0.9	38.4	0.9	30.8	0.8	27.8	0.7	26.4	0.7	25.3	ns
		Bn to An	0.9	38.4	0.9	30.8	0.8	27.8	0.7	26.4	0.7	25.3	ns
t <sub>dis</sub>	disable time	$\overline{\text{OE}}$ to An	1.5	50.3	1.5	50	1.5	50.2	1.5	50.4	1.4	50.3	ns
		$\overline{\text{OE}}$ to Bn	1.5	50.3	1.5	50	1.5	50.2	1.5	50.4	1.4	50.3	ns
t <sub>en</sub>	enable time	$\overline{\text{OE}}$ to An	0.4	67.2	0.4	61.8	0.4	58.5	0.4	58.2	0.4	57.1	ns
		$\overline{\text{OE}}$ to Bn	0.4	67.2	0.4	61.8	0.4	58.5	0.4	58.2	0.4	57.1	ns
<b>V<sub>CC(A)</sub> = 2.5 V ± 0.2 V</b>													
t <sub>pd</sub>	propagation time	An to Bn	1.2	33.4	1.2	25.4	1.0	19.7	1.0	18.5	0.9	17.3	ns
		Bn to An	1.2	33.4	1.2	25.4	1.0	19.7	1.0	18.5	0.9	17.3	ns
t <sub>dis</sub>	disable time	$\overline{\text{OE}}$ to An	1.4	29.1	1.4	28.8	1.4	29	1.4	29.2	1.4	29.1	ns
		$\overline{\text{OE}}$ to Bn	1.4	29.1	1.4	28.8	1.4	29	1.4	29.2	1.4	29.1	ns
t <sub>en</sub>	enable time	$\overline{\text{OE}}$ to An	1.0	42.3	1.0	36.8	1.0	33.4	1.0	32.1	1.0	31.0	ns
		$\overline{\text{OE}}$ to Bn	1.0	42.3	1.0	36.8	1.0	33.4	1.0	32.1	1.0	31.0	ns
<b>V<sub>CC(A)</sub> = 3.3 V ± 0.3 V</b>													
t <sub>pd</sub>	propagation time	An to Bn	0.8	32.2	0.8	23.2	0.8	16.8	0.7	15.5	0.6	14.6	ns
		Bn to An	0.8	32.2	0.8	23.2	0.8	16.8	0.7	15.5	0.6	14.6	ns
t <sub>dis</sub>	disable time	$\overline{\text{OE}}$ to An	1.6	24.2	1.6	23.9	1.6	24.1	1.6	24.3	1.6	24.2	ns
		$\overline{\text{OE}}$ to Bn	1.6	24.2	1.6	23.9	1.6	24.1	1.6	24.3	1.6	24.2	ns
t <sub>en</sub>	enable time	$\overline{\text{OE}}$ to An	0.8	35.5	0.8	29.5	0.8	26.3	0.8	25.2	0.8	24.8	ns
		$\overline{\text{OE}}$ to Bn	0.8	35.5	0.8	29.5	0.8	26.3	0.8	25.2	0.8	24.8	ns
<b>V<sub>CC(A)</sub> = 5.0 V ± 0.5 V</b>													
t <sub>pd</sub>	propagation time	An to Bn	0.7	30.4	0.7	22.1	0.4	15.5	0.3	13.4	0.3	11.9	ns
		Bn to An	0.7	30.4	0.7	22.1	0.4	15.5	0.3	13.4	0.3	11.9	ns
t <sub>dis</sub>	disable time	$\overline{\text{OE}}$ to An	0.3	19.6	0.3	19.3	0.3	19.5	0.3	19.7	0.3	19.6	ns
		$\overline{\text{OE}}$ to Bn	0.3	19.6	0.3	19.3	0.3	19.5	0.3	19.7	0.3	19.6	ns
t <sub>en</sub>	enable time	$\overline{\text{OE}}$ to An	0.7	33.1	0.7	24.9	0.7	22.4	0.7	20.9	0.7	19.9	ns
		$\overline{\text{OE}}$ to Bn	0.7	33.1	0.7	24.9	0.7	22.4	0.7	20.9	0.7	19.9	ns

[1] t<sub>pd</sub> is the same as t<sub>PLH</sub> and t<sub>PHL</sub>; t<sub>dis</sub> is the same as t<sub>PLZ</sub> and t<sub>PHZ</sub>; t<sub>en</sub> is the same as t<sub>PZL</sub> and t<sub>PZH</sub>.

## 74LVC8T245; 74LVCH8T245

### 8-bit dual supply translating transceiver; 3-state

**Table 9. Typical power dissipation capacitance at  $V_{CC(A)} = V_{CC(B)}$  and  $T_{amb} = 25\text{ °C}$**

Voltages are referenced to GND (ground = 0 V). [1][2]

Symbol	Parameter	Conditions	$V_{CC(A)}$ and $V_{CC(B)}$				Unit
			1.8 V	2.5 V	3.3 V	5.0 V	
$C_{PD}$	power dissipation capacitance	A port: (direction A to B); B port: (direction B to A)	1	1	1	1	pF
		A port: (direction B to A); B port: (direction A to B)	16	16	17	18	pF

[1]  $C_{PD}$  is used to determine the dynamic power dissipation ( $P_D$  in  $\mu W$ ).

$$P_D = C_{PD} \times V_{CC}^2 \times f_i \times N + \sum(C_L \times V_{CC}^2 \times f_o) \text{ where:}$$

$f_i$  = input frequency in MHz;

$f_o$  = output frequency in MHz;

$C_L$  = output load capacitance in pF;

$V_{CC}$  = supply voltage in V;

$N$  = number of inputs switching;

$\sum(C_L \times V_{CC}^2 \times f_o)$  = sum of outputs.

[2]  $f_i = 10\text{ MHz}$ ;  $V_i = \text{GND to } V_{CC}$ ;  $t_r = t_f = 1\text{ ns}$ ;  $C_L = 0\text{ pF}$ ;  $R_L = \infty\ \Omega$ .

### 10.1. Waveforms and test circuit

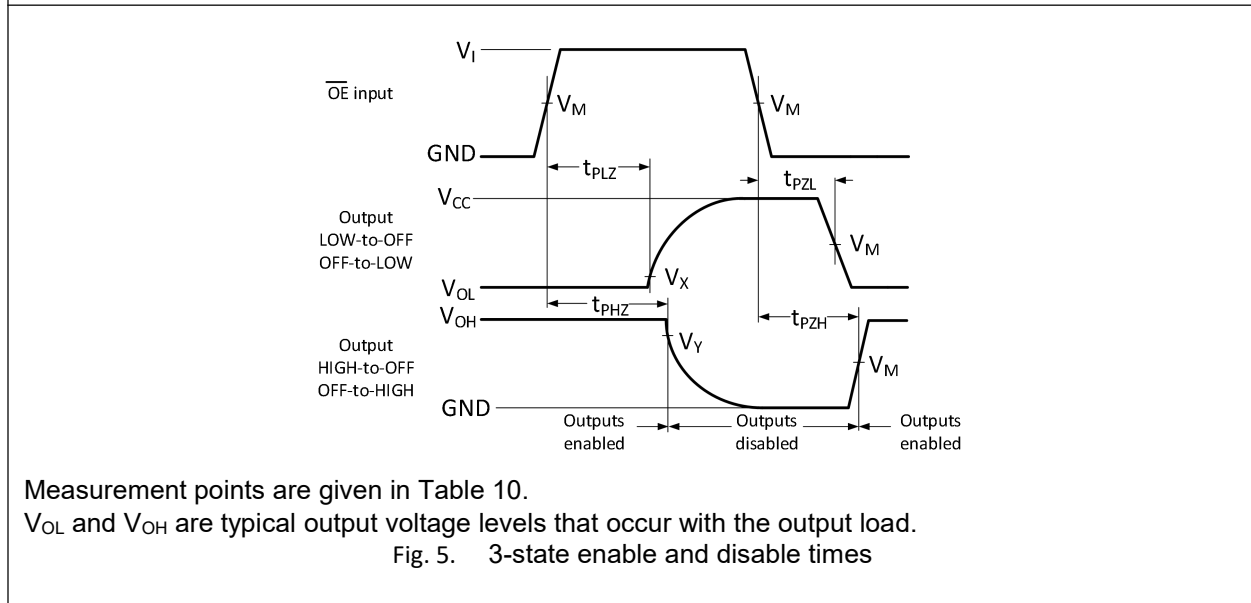
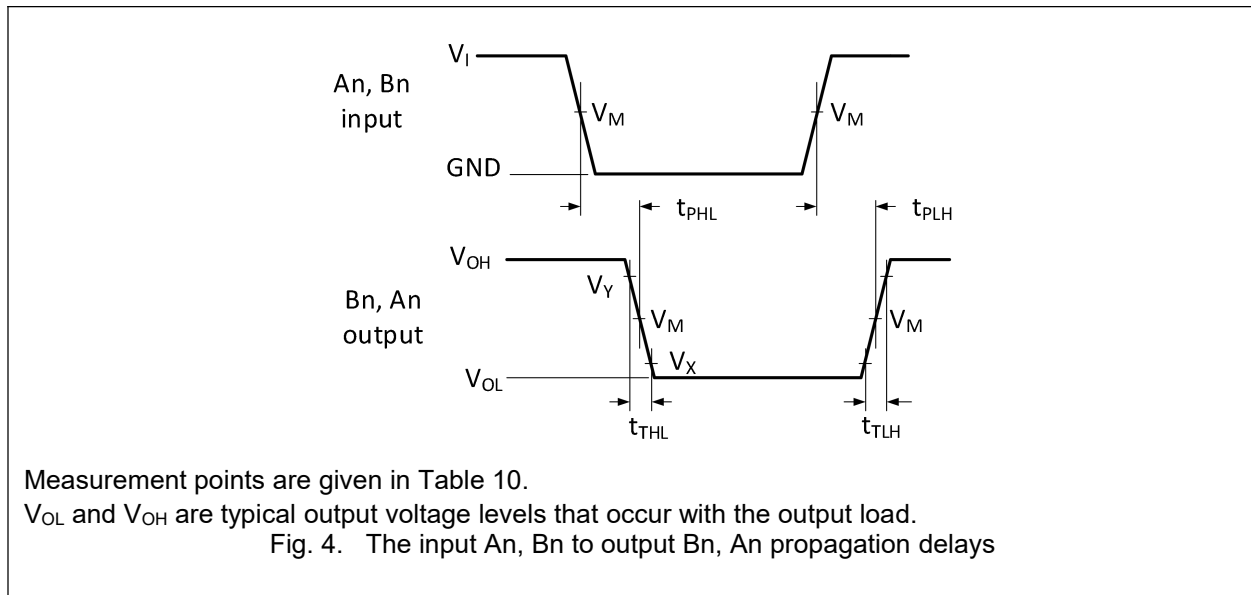

**Table 10. Measurement points**

Supply voltage	Input [1]	Output [2]		
$V_{CC(A)}, V_{CC(B)}$	$V_M$	$V_M$	$V_X$	$V_Y$
1.2 V to 1.6 V	$0.5V_{CC1}$	$0.5V_{CC0}$	$V_{OL} + 0.1 V$	$V_{OH} - 0.1 V$
1.65 V to 2.7 V	$0.5V_{CC1}$	$0.5V_{CC0}$	$V_{OL} + 0.15 V$	$V_{OH} - 0.15 V$
3.0 V to 5.5 V	$0.5V_{CC1}$	$0.5V_{CC0}$	$V_{OL} + 0.3 V$	$V_{OH} - 0.3 V$

[1]  $V_{CC1}$  is the supply voltage associated with the data input port.

[2]  $V_{CC0}$  is the supply voltage associated with the output port.

# 74LVC8T245; 74LVCH8T245

## 8-bit dual supply translating transceiver; 3-state

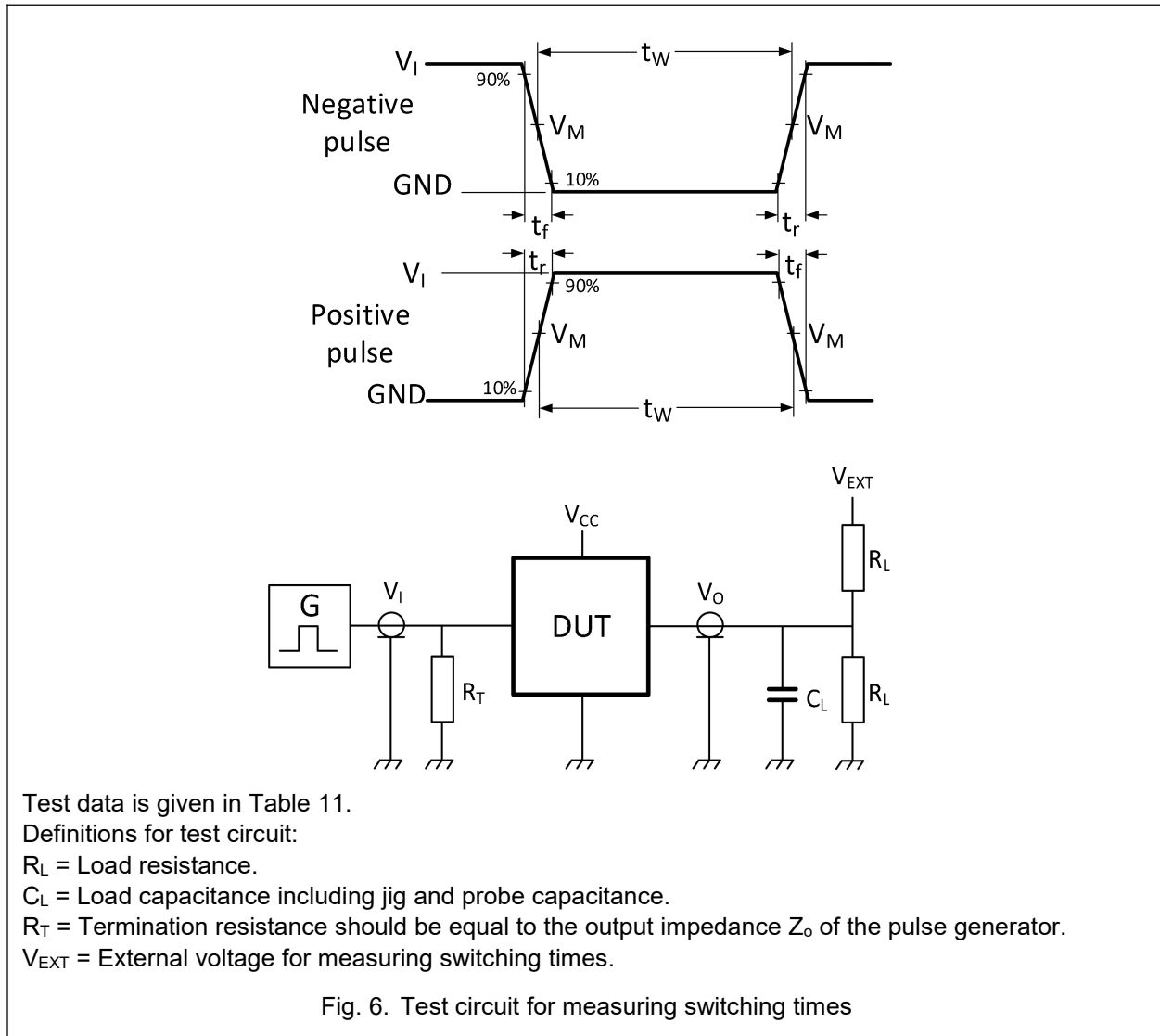

**Table 11. Test data**

Supply voltage	Input		Load		$V_{EXT}$		
$V_{CC(A)}, V_{CC(B)}$	$V_I$ [1]	$t_r = t_f$	$C_L$	$R_L$	$t_{PLH}, t_{PHL}$	$t_{PZH}, t_{PHZ}$	$t_{PZL}, t_{PLZ}$ [2]
1.2 V to 5.5 V	$V_{CCI}$	$\leq 2.5$ ns	15 pF	2k $\Omega$	open	GND	2 $V_{CCO}$

[1]  $V_{CCI}$  is the supply voltage associated with the data input port.

[2]  $V_{CCO}$  is the supply voltage associated with the output port.

# 11. Package Outline

## TSSOP-24L

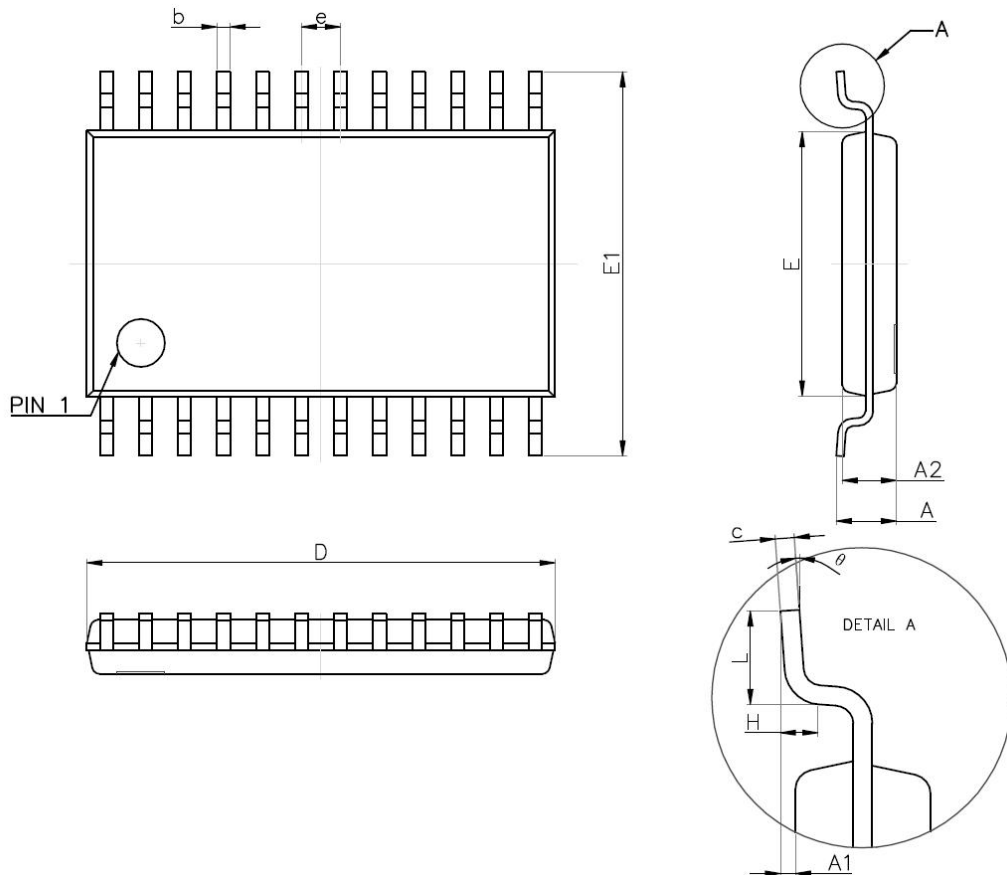

Symbol	Dimensions In Millimeters		Dimensions In Millimeters	
	Min.	Max.	Min.	Max.
A	-	1.20	6.20	6.60
A1	0.05	0.15	0.65BSC	
A2	0.80	1.05	0.45	0.75
A3	0.39	0.49	1.00REF	
b	0.20	0.28	0°	8°
b1	0.19	0.25		
c	0.13	0.17		
c1	0.12	0.14		
D	6.40	6.60		
E1	4.30	4.50		

## 12. Abbreviations

**Table 12. Abbreviations**

Acronym	Description
CMOS	Complementary Metal-Oxide Semiconductor
DUT	Device Under Test
ESD	ElectroStatic Discharge
HBM	Human Body Model
CDM	Charged Device Model

## 13. Revision History

**Table 13. Revision history**

Document ID	Release Date	Data sheet status	Change notice	Supersedes
74LVC_LVCH8T245 Rev. 1.0	Feb 10, 2025	Product datasheet		